

COBY®

MODEL NO: CX-CD248

Portable AM/FM Radio, Cassette Recorder and CD Player

LOCATION OF CONTROLS

- | | |
|-------------------------|--------------------------------------|
| 1. Volume Control | 7. Band Selector |
| 2. Function Selector | 8. Tuning Control |
| 3. CD Display | 9. Cassette Operation Buttons |
| 4. CD Operation Buttons | 10. CD Compartment Open/Close Button |
| 5. Cassette Compartment | 11. Tuning Indicator Window |
| 6. CD Compartment | 12. Telescopic Antenna |

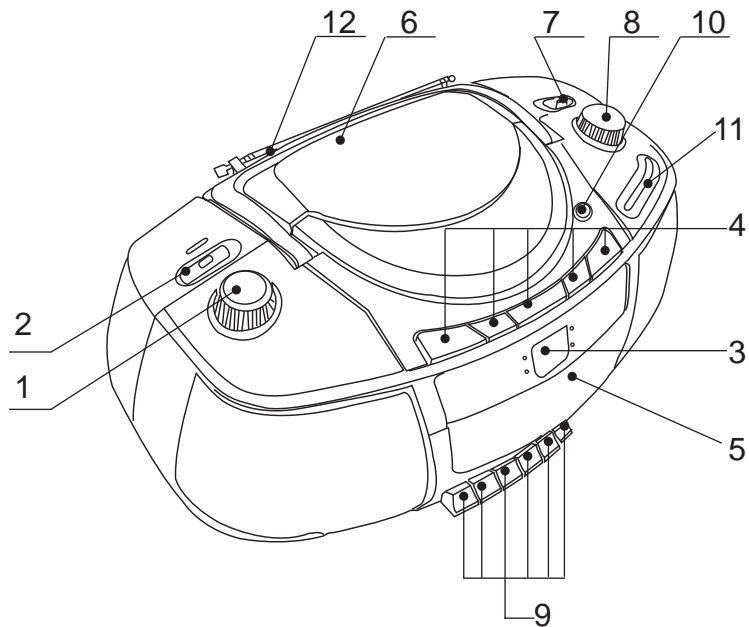
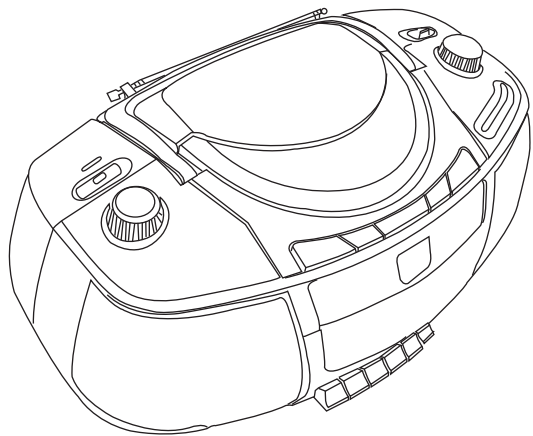

Please read instruction manual before use.

IMPORTANT SAFEGUARDS

Always operate the product from a power supply of the same voltage, frequency and rating as indicated on the product identification plate.

Do not operate product with a damaged cord or plug. Never install the unit where there are heat sources such as radiators, heat registers, stoves, direct sunlight, excessive dust or where there is mechanical vibration or shock. Switch off and unplug from AC outlet when not in use.

IMPORTANT

The CD mechanism and the sensitive circuitry may cause interference to a radio tuner nearby. Do not operate this unit while operating other radio devices.

Danger This product utilizes invisible laser radiation. Avoid direct exposure to the beam.



Caution Use of controls, adjustments or procedures not listed in this manual may result in hazardous radiation exposure.

CONCERNING COMPACT DISCS

Only compact discs identified with this mark can be used with this player.



CARE and MAINTENANCE

Handle your unit with care to extend the life of the unit. Use a soft and clean cloth dampened with plain lukewarm water to clean the exterior of the unit.

Never use solvents such as benzene or other strong chemical cleaners since these could damage your unit.

It is important that no liquid reaches the inside of the unit.

Do not touch the CD laser part or look directly at it.

INTRODUCTION

Please read and follow the instruction manual carefully before operating in order to avoid any damage to the unit.

POWER SUPPLY

1. By using AC power

Insert one end of the AC power cord into the AC socket on the rear of the unit and the other end into a standard wall socket.

2. By using batteries

Insert 8x"D" size batteries (not included) in the battery compartment in the back of the unit by matching the polarities.

- The unit will not operate on battery power when the AC power cord is plugged into the AC socket.
- Replace batteries when the power indicator dims, the volume decreases or the sound distorts.
- Use batteries of high quality and check them regularly. Alkaline batteries are recommended.
- Do not mix new batteries with old or used batteries.
- Use only batteries of the same brand and type
- Batteries should not be left in the unit if they are exhausted or if the unit is not to be used for a long period of time as they may leak and damage the unit. Battery leakage is not covered under the warranty.

HEADPHONES (Not included)

You can use headphones with 3.5mm diameter stereo plug and have impedance of 32ohms. When the headphones are connected, the speakers are disconnected automatically.

Set the VOLUME to a low level before using headphones and gradually adjust the Volume Control to the comfortable listening level.

Do not play the VOLUME too loud for extended periods of time to avoid any damage your hearing.

RADIO OPERATION

1. Slide the Function Selector switch to radio.
2. Select the desired AM or FM with the band switch.
3. Tune the desired station by turning the Tuning Control.
4. Adjust the volume with Volume Control as desired.
5. Extend Telescopic Antenna and adjust the direction and angle to obtain the optimum reception.
6. Set the Function Switch to Tape for power standby mode.

CD OPERATION

Set the FUNCTION Selector to the CD position and insert a CD.

●Play/Stop/Pause Mode

1. Press PLAY/PAUSE button to play.
2. Press PLAY/PAUSE button to pause while in play mode.
3. Press PLAY/PAUSE button once more to resume play.
4. Press STOP to stop play.
5. Always press STOP and wait for complete stop to remove CD from CD player.

●Repeat Mode

1. Press Repeat button once to repeat current track only, the indicator is lighting and keeping on. twice to repeat all tracks, the indicator is flashing.
2. Press Repeat button twice to cancel repeat current track. Or once to cancel repeat all tracks.

●Program Function (REPEAT function will change into PROGRAM function at stop mode)

To program:

- (1) Press REPEAT button at stop mode, "REPEAT" indicatorlight will flash, the serial number for programming frozen at the same time.
 - (2) Press FF **⏮** (orREW **⏭**) button to select the track number.
 - (3) When desired track is displayed, press REPEAT button to confirm.
 - (4) Repeat (2)~ (3) to set up 16 tracks. The display will show the current set track.
 - (5) Set tracks can be reviewed by pressing REPEAT button.
 - (6) To complete the programming and to play, press PLAY/PAUSE button to start the programmed tracks.
- (5) To clear the programming, press STOP(**■**) button.

Note: After setting up to 10 tracks(P0-P9), the letters "a-b-c-d-e-f"(Pa-Pf) will replace the digits "11-12-13-14-15-16", because the LCD can only display two digits at most.

●Tracking Mode

1. To go back to beginning of current track, press **⏮** once.
2. To go back to previous tracks, press **⏮** repeatedly.
3. To go to next track, press **⏭** once or repeatedly to play your desired track.

CASSETTE TAPE OPERATION

1. Set the FUNCTION Selector to the TAPE (OFF) position.
2. Press STOP/EJECT to open the tape deck door. Insert a tape and close the door.
3. Press PLAY to start play, the tape will stop automatically at the end.
4. Press **⏮** to rewind or press **⏭** to fast forward tape.
5. Press STOP/EJECT to stop play.
6. Press STOP/EJECT one more time to open the cassette door and take the tape out.
7. Adjust the sound with the VOLUME control.

We recommend that you use only type1 (Normal Bias) cassette tape with your tape player.

RECORDING FROM RADIO/CD

This unit is equipped with ALC (Automatic Level control) circuitry that automatically sets the recording to the optimum level.

Adjusting the VOLUME control does not effect the recording.

We recommend that the unit be powered by AC (house current) when recording since this function uses the most power. We recommend that you use Type 1 (normal bias) cassette tapes only.

●Recording from Radio

- 1.Set the FUNCTION Selector to the RADIO position.
- 2.Set the BAND Selector to AM or FM.
- 3.Turn the TUNING Dial to tune in a radio station.
- 4.Open the cassette deck door and insert the blank tape.
- 5.Press PAUSE, then press RECORD, the PLAY key is automatically engaged with RECORD button.
- 6.Release the PAUSE button to begin recording. You can use the PAUSE button to edit any unwanted commercials or programs during your recording.
- 7.Recording will stop automatically at the end of the tape or press STOP to end the recording manually.

● Recording from CD

- 1.Set the FUNCTION selector to the CD position.
- 2.Insert a CD.
- 3.Open the cassette deck door and insert the blank tape.
- 4.Press RECORD and the PLAY key is automatically engaged.
- 5.Press the PLAY/PAUSE button on the CD player, the Play/Pause indicator will illuminate.
- 6.Press the STOP button to manually end recording or it will stop automatically at the end of recording.

SPECIFICATIONS

Power Sourc	: AC 110/220V 50/60Hz 10W DC 12V (8x"D" size batteries)(not included)
Speakers	: 4" Wide range, 4ohm
Output Power	: 2x2W
Weight	: 8 lbs (batteries not included)

Tape Player/Recorder

Tape	: Standard normal bias
Frequency Response	: 125-6300Hz

Radio

Frequency Response	: FM 88-108MHz
	AM 530-1600KHz

CD Player

Laser Wavelength	: 760-800NM
Tracking Method	: 3-spot error detection/3.86mm lens

PROP. 65 WARNING:
Handling the coated electrical wires of this product exposes you to lead, a chemical known to the State of California to cause cancer, birth defects and other reproductive harm.
Wash hands after use.